

Features

- Design : Suspended Stripline
- Stainless Steel Connectors
- Low Insertion Loss 2.0 dB
- High Rejection
- RoHS and REACH Compliant

Electrical Specifications

Description	Units	Minimum	Typical	Maximum
Freq. Range	GHz	15	17	19
Bandwidth	MHz		4000	
Insertion Loss	dB			2.0
Ripple	dB			2.0
Return Loss	dB	9.54		
Group delay	ns			-
Group Delay Variation	ns			-
Phase Linearity	deg			-
Amplitude Matching	dB			-
Rejection	dB	50@DC-10GHz	50@30-40GHz	
Power	W			10
Operating Temp.	°C	-40		+70

Special Requirements

Note

- Electronic Specification Note : Values at 25deg , sea level. Test indicators will deteriorate at high and low temperature ;
- Relative Humidity 5 to 95% at +25°C ;

Mechanical Specifications

Dimension L*W*H	45*17*10 mm
Input Connector	SMA-Female Stainless Steel
Output Connectors	SMA-Female Stainless Steel
Weight	TBD g
Finishing	Paint Black
Environment	X

Compliance Certifications

RoHS Compliant	✓
REACH Compliant	✓

CAD Drawing

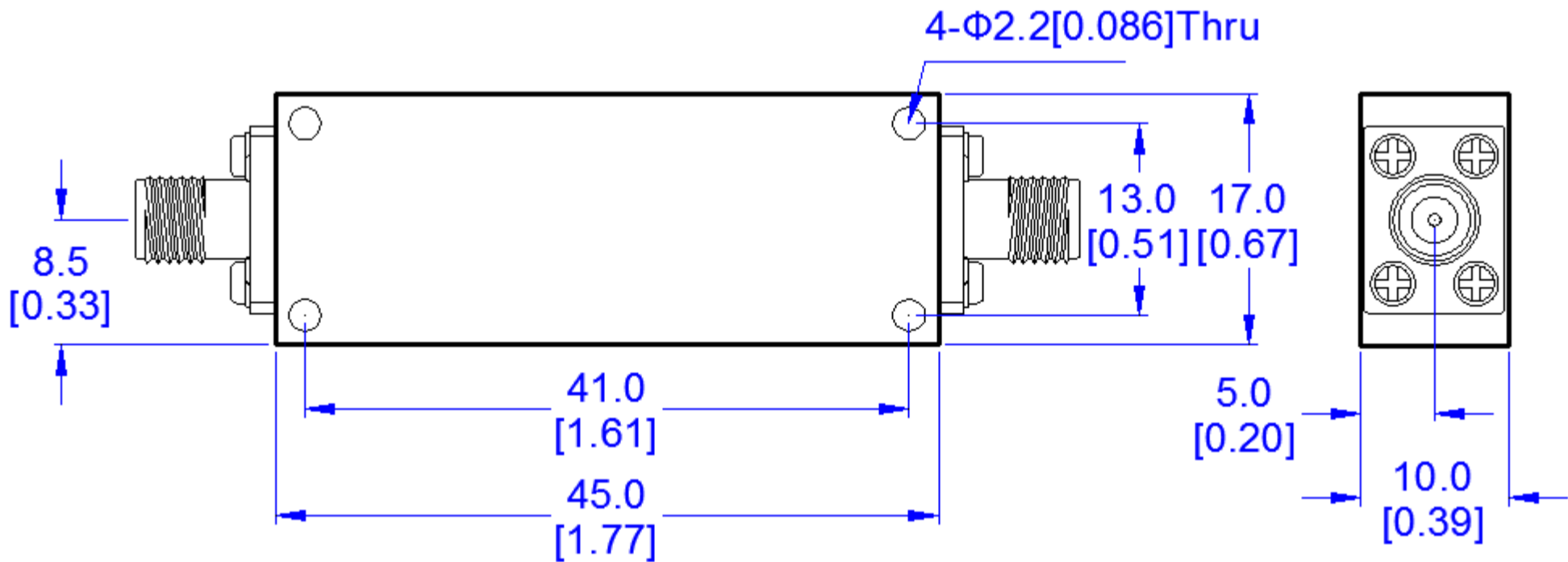

Dimensions are in mm [Inches]
 Tolerances : Outline drawing: ±0.2 [0.008]
 Hole: ±0.2 [0.008]