

Features

- Small Signal Gain 18dB
- Low Gain Flatness
- Input VSWR 2
- Output Power 3dBm
- RoHS and REACH Compliant

Electrical Specifications

Description	Units	Minimum	Typical	Maximum
Freq. Range	GHz	0.5		6
Max input Power	dBm			20
Small Signal Gain	dB	18		
Gain Flatness	dB			1.5
Noise figure	dB			3
Output Power @P1dB	dBm	3		
Input VSWR	: 1			2
Output VSWR	: 1			2
OIP3	dBm		15	
TTL Control				
TTL Switching Time	us			
Supply Current (Vcc=12V)	mA		150	
Operating Temp.	°C			

Special Requirements

Note

- Electronic Specification Note : Values at 25deg , sea level. Test indicators will deteriorate at high and low temperature ;
- ESD sensitive material , Transport material in approved ESD bags. Handle only in approved ESD workstation;
- Providing effective cooling measures and electrostatic protection;
- If the product is damaged due to over-drive, no-load, over-temperature, over-current and static electricity in use. Customer needs to pay for the cost of maintenance.

Mechanical Specifications

Dimension L*W*H	34.4*16.8*14 mm
Input Connector	SMA-Female
Output Connector	SMA-Female
Weight	20 g
VDC Connector	
Finishing	Self-colour Anodizing
Environment	X

Compliance Certifications

RoHS Compliant	✓
REACH Compliant	✓

CAD Drawing

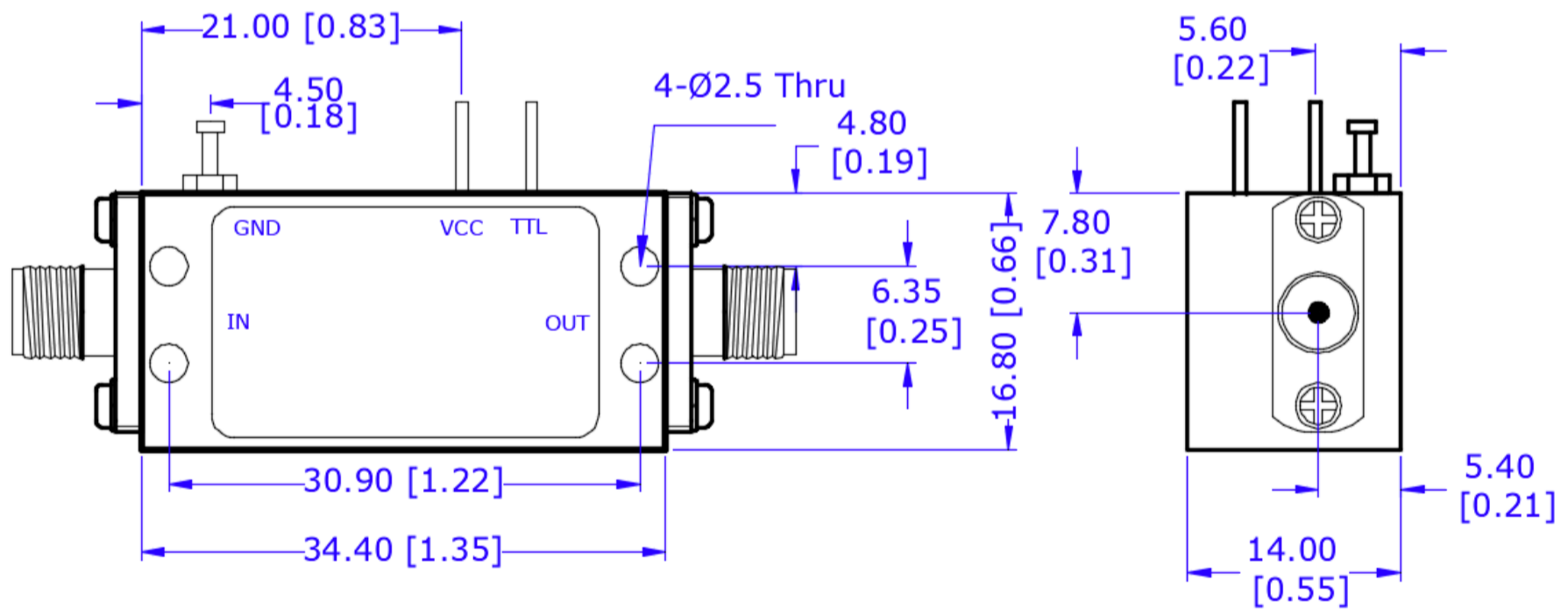

Dimensions are in mm [Inches]
 Tolerances : Outline drawing: ±0.2 [0.008]
 Hole: ±0.2 [0.008]